



4 FOOT TRAIL BENCH

- DL-TB-4-RPW** Trail Bench with Back
- DL-TBS-4-RPW** Trail Bench Seat

The Trail Bench is made with recycled wood seating planks, a power coated frame finish and zinc plated hardware. Available in both surface and portable mounts. Multiple colors available. Shown in Nutmeg.

PRODUCT DIMENSIONS

with Back: 48" L x 15.5" W x 32" H
Seat: 48" L x 15.5" W x 20" H

MATERIALS

Recycled Wood-like: Made of 95% recycled plastic. UV additives to prevent deterioration from exposure to sunlight.

WARRANTY

50 year material warranty

MOUNTING OPTIONS

Surface or in-ground mount

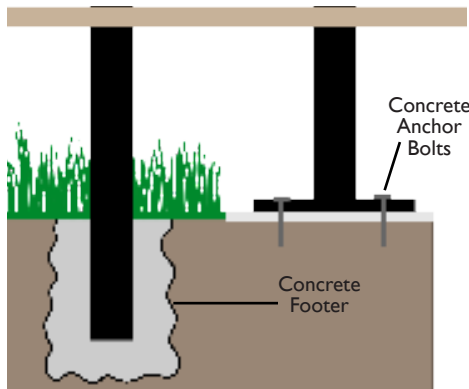

IN-GROUND MOUNT

SURFACE MOUNT



4 FOOT TRAIL BENCH

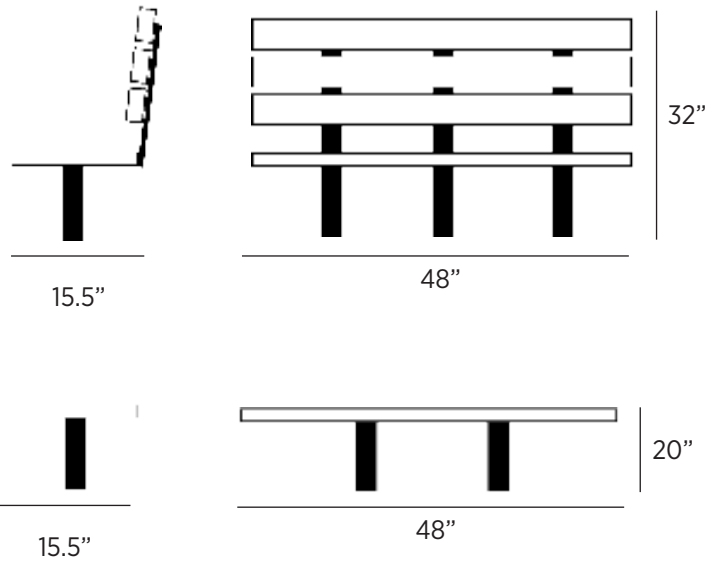

COLOR OPTIONS

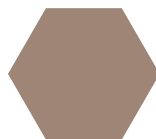

Nutmeg



Taupe



Red



Blue



**ASSEMBLY AND MOUNTING INSTRUCTIONS
TRAIL BENCH WITH BACK
DL-TB-6-RPW AND DL-TB-4-RPW**

1. Set up two support frame weldments on a smooth, level surface roughly 62 inches apart on centers laying them on their back with seat in a vertical direction. Center the third weldment between them. See diagram 1.
2. Mark each plate at a distance of 2 7/8, 7, and 11 1/4 inches from the end of the plate. Diagram 2.
3. Locate bull nose board on the weldment at a distance of 3 1/4 inches from end of the board to edge of weldment plate and flat edge on the 11 1/4 inch mark. Make certain curved edge is facing bend in plate.
4. Clamp board to weldment and locate the second weldment at distance of 34 1/4 inches from end of board and the board flat edge on the 11 1/4 inch mark. Clamp board to weldment. Diagram 2.
5. Locate the third weldment at distance of 65 1/4 inches from end of board and the board flat edge on the 11 1/4 inch mark. Clamp weldment to board. See diagram 2.
6. Drill 5/32 diameter pilot hole (six places) into the board and install six 1/4 x 2 screws into the board (use fourth line of 2 holes in metal plate of weldments as a drill guide).
7. Set one rectangular board at a distance of 3 1/4 inches from plate side edge to end of board with flat edge on the 7 inch marks. Place a 3/4 inch thick spacer between the bull nose and rectangular board at each end to maintain 3/4 inch gap. Clamp board in place. See diagram 2.
8. Drill 5/32 diameter pilot hole (six places) into the board and install six 1/4 x 2 screws into the board (use third line of 2 holes in metal plate of weldment as a drill guide).
9. Set the second rectangular board at a distance of 3 1/4 inches from plate side edge to end of board with flat edge of board on 2 7/8 inch mark. Place a 3/4 inch thick spacer between the two rectangular boards at each end to maintain 3/4 inch gap. See diagram 2.
10. Drill 5/32 diameter pilot hole (six places) into the board and install six 1/4 x 2 screws through washers into the board (use second line of 2 holes in metal plate of weldments as a drill guide).
11. Locate second bull nose board at a distance of 3 1/4 inches from plate side edge to end of board and at a gap distance of 3/4 inch between bull nose and rectangular board. Place a 3/4 inch thick spacer between the bull nose and rectangular board at each end to maintain 3/4 inch gap. See diagram 2.
12. Drill 5/32 diameter pilot hole (six places) into the board and install six 1/4 x 2 screws through washers into the board (use first line of 2 holes in metal plate of weldments as a drill guide).
13. Check squareness of boards with plates with hand square before tightening screws.
14. Set the bench upright to fasten the boards on the back. See diagram 3.
15. Mark each plate at a distance of 2 7/8, 7 1/8 inches from the end of the plate. Diagram 2
16. Locate one bull nose board on the weldments at a distance of 3 1/4 inches from end of the board to edge of weldment plate with flat edge of board on the 7 1/8 inch marks. Make certain curved edge is facing bend in plate. Clamp board in place. See diagram 3. **IMPORTANT:** Make sure that the distance between the two bull nose boards where seat meets the back measures 4 inches or less. Adjust the board on the back to meet 4 inch maximum dimension.
17. Drill 5/32 diameter pilot hole (six places) into the board and install six 1/4 x 2 screws into the board (use third line of 2 holes in metal plate of weldments as a drill guide). Diagram 3.
18. Set one rectangular board at a distance of 3 1/4 inches from plate side edge to end of board with flat edge of board on the 2 7/8 inch mark. Clamp board in place. Place a 3/4 inch thick spacer between the bull nose and rectangular board at each end to maintain 3/4 inch gap. See diagram 3.
19. Drill 5/32 diameter pilot hole (six places) into the board and install six 1/4 x 2 screws into the board (use second line of 2 holes in metal plate of weldments as a drill guide). Diagram 3.
20. Locate second bull nose board at a distance of 3 1/4 inches from plate side edge to end of board with a gap distance of 3/4 inches between bull nose and rectangular boards at both ends. Place a 3/4 inch thick spacer between the bull nose and rectangular board at each end to maintain 3/4 inch gap. Clamp board in place. See diagram 3.
21. Drill 5/32 diameter pilot hole (four places) into the board and install four 1/4 x 2 screws into the board (use first line of 2 holes in metal plate of weldments as a drill guide). Diagram 3.
22. Check squareness of boards with plates before tightening all screws.

DIAGRAM 1

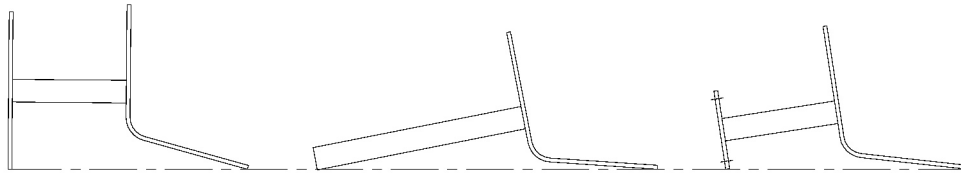

DIAGRAM 2: ATTACHING SEAT BOARDS

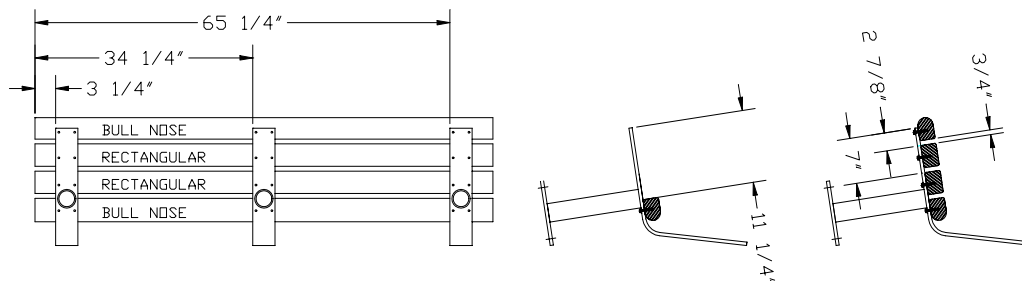
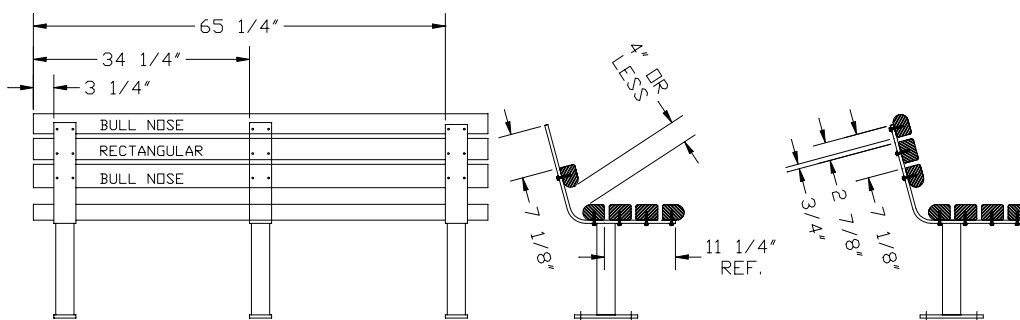

DIAGRAM 3: ATTACHING BACK BOARDS



1. Surface mount bench with 1/2 inch anchors into concrete surface at dimensions as shown on diagram 3.
2. Embedded mount bench by setting in filled holes at dimensions as shown on diagram 3.
3. Portable bench will rest on any flat, even surface-no mounting required

DIAGRAM 4: SHOWN ARE

**SURFACE CONCRETE ANCHORS 4 PLACES
EMBEDDED HOLES 2 PLACES
PORTABLE NO MOUNTING**

SURFACE

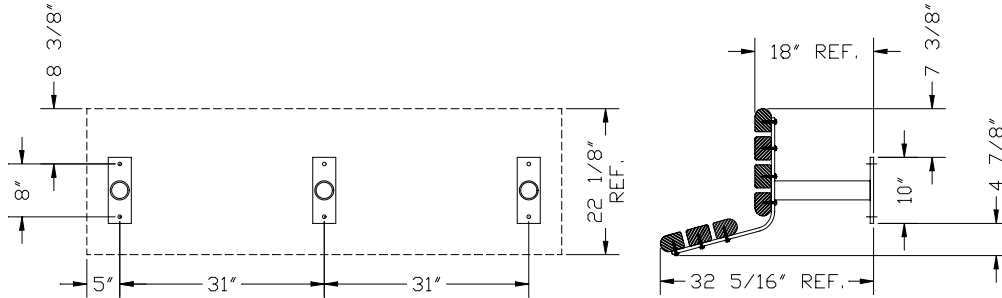

EMBEDDED

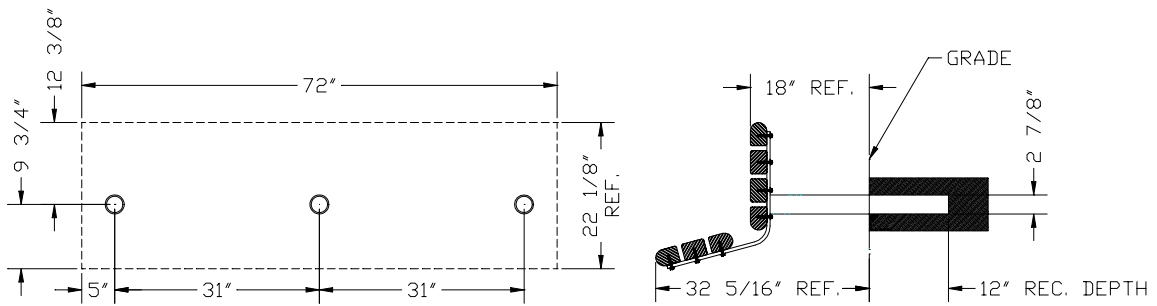

PORTABLE

