



FIRE HYDRANT | DL-FH30-FG

The Fire Hydrant is the dog's favorite spot to hang out. Why? We may never know. This decorative park piece will certainly be the social spot of the park!

KEY FEATURES

PRODUCT DIMENSIONS

- DIMENSIONS (L x W x H): 13"x 13" x 33"
- WEIGHT: 17 lbs

SHIPPING DIMENSIONS

- SHIPPING (L x W x H): 40"x 14"x 14"
- MOUNT TYPE: Surface Mount

MOUNTING

- 4 1/2" holes for mounting
- LAWN INSTALLATION: Galvanized or plastic/vinyl landscape spikes (not included)
- CONCRETE INSTALLATION: Concrete anchor bolts (not included)

WARRANTY

One year manufacturer warranty for defects. Other issues are under the manufacturer's discretion.



FIRE HYDRANT

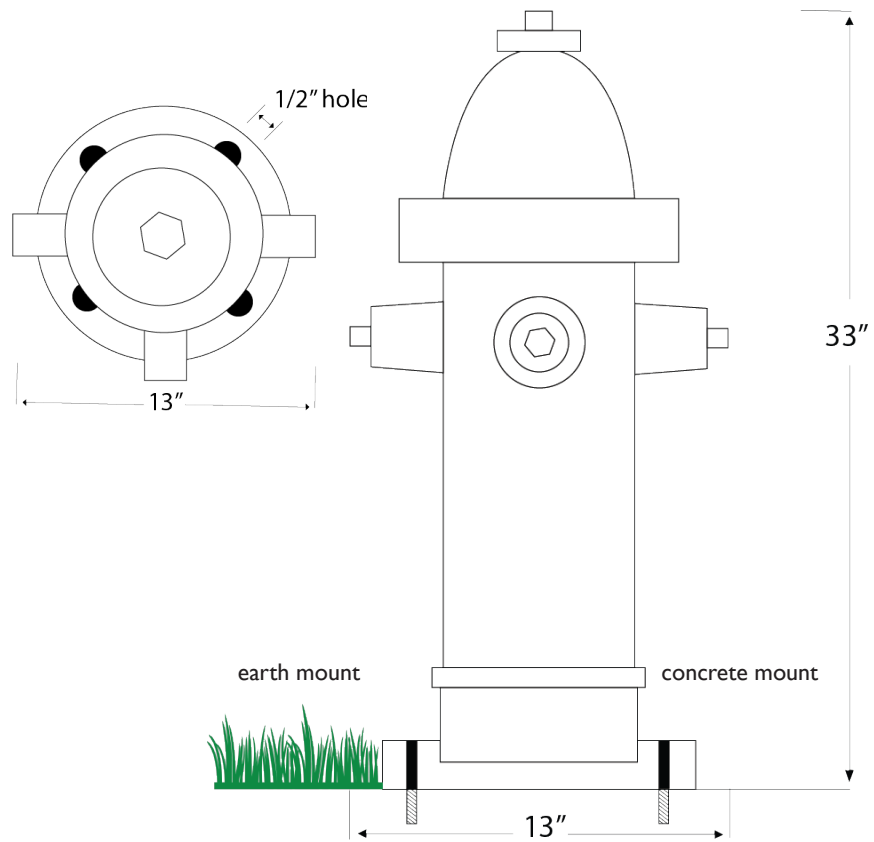

ITEM # DL-FH30-FG

COLOR OPTIONS

Red or Black & Silver

